



Broco products are built with your safety in mind, but it is the responsibility of the operator to exercise good work practices and common sense.

WARNING: You must read and understand these operating instructions thoroughly and follow the procedures contained herein before attempting to use the Broco GOWELD portable welder. Failure to do so can result in death, serious injury, property damage or poor performance.

IF YOU HAVE ANY QUESTIONS REGARDING THE SAFE OPERATION OF PRODUCTS, STOP! DO NOT ATTEMPT TO OPERATE! Contact Broco, Inc., Tel: 800-845-7259 / 909-483-3222, fax: 909-483-3233, for technical assistance.

OPERATING INSTRUCTIONS MANUAL

GOWELD Portable Welder
DC Only Input: 42 VDC 300A MAX
Made in the U.S.A. by:

Broco, Inc.
8690 Red Oak St.
Rancho Cucamonga, CA 91730-4819
Tel: 909 483 3222 Fax: 909 483 3233
Toll Free: 800 845 7259
E-mail Sales @Brocoinc.com
www.brocoinc.com



WARNING:

ARC WELDING CAN BE HAZARDOUS. PROTECT YOURSELF AND OTHERS FROM POSSIBLE SERIOUS INJURY OR DEATH. KEEP CHILDREN AWAY. PACEMAKER WEARERS MUST CONSULT THEIR DOCTORS BEFORE OPERATING. WEAR PROPER FACE AND EYE PROTECTION, APPROPRIATE PROTECTIVE (FLAME OR SPARK RESISTANT) CLOTHING, FOOTWEAR AND GLOVES. DO NOT BREATHE WELDING FUMES AND GASES.

- ? ELECTRIC & MAGNETIC FIELDS MAY BE DANGEROUS.
- ? ELECTRIC SHOCK CAN KILL.
- ? ARC RAYS CAN BURN EYES & EXPOSED SKIN.
- ? FUMES & GASES CAN BE DANGEROUS.
- ? WELDING SPARKS CAN CAUSE FIRE & EXPLOSION.
- ? GAS CYLINDERS CAN EXPLODE IF DAMAGED.

WARNING:

Welding equipment is potentially dangerous to the operator and persons in the area and must be used in strict accordance with the instructions provided. Read the instruction manual before using GOWELD. Welding should be performed by trained individuals only and according to industry accepted safety practices.

© 2002 by BROCO, INC. all rights reserved. This manual may not be reproduced in whole or in part without the express written permission of Broco, Inc.

TABLE OF CONTENTS

Chapter 1 SAFETY PRECAUTIONS AND GENERAL INFORMATION

Section I. INTRODUCTION

- 1-1. WELDING PROCESS
- 1-2. WARNINGS
- 1-3. SAFETY PRECAUTIONS

Section II. EQUIPMENT DESCRIPTION

- 1-4. GOWELD WELDER FEATURES

Chapter 2 PREPARATION

Section I. SETUP PROCEDURES

- 2-1. PREPARING THE WORK AREA
- 2-2. PRE-ASSEMBLY INSPECTION

Section II. GOWELD SETUP

- 2-3. LOADING THE WIRE
 - 2-3-1. Wire selection.
 - 2-3-2. Contact tip.
 - 2-3-3. Loading electrode / wire drive
 - 2-3-4. Tension roller pressure setting.
- 2-4. CABLE CONNECTIONS
 - 2-4-1. Harness to power source.
 - 2-4-1-1. Batteries.
 - 2-4-2. GOWELD to harness.
 - 2-4-2-1. Choosing polarity.
 - 2-4-2-2. Power & ground leads.
- 2-5. GAS CONNECTION

SAFETY
INFORMATION

PREPARATION

OPERATION

MAINTENANCE

TROUBLESHOOTING

2-5-1. Regulator adjustment.

2-5-2. Gas hose connection.

Chapter 3 OPERATING INSTRUCTIONS

Section I. INTRODUCTION

3-1. TORCH OPERATION

Section II. OPERATING PROCEDURES

3-2. WELDING CAPABILITY

3-3. CONTROLS & SETTINGS

3-3-1. Wire speed control.

3-3-2. Voltage control.

3-3-3. LED indicators.

3-4. SEQUENCE OF OPERATION

3-5. WELDING TECHNIQUES

3-6. AUTOMATIC PROTECTION SHUTDOWN

3-7. SHUTDOWN PROCEDURES

Chapter 4 SCHEDULED MAINTENANCE

Section I. INTRODUCTION

4-1. PREVENTIVE MAINTENANCE

Section II. SCHEDULED MAINTENANCE

4-2. PREVENTIVE MAINTENANCE
PROCEDURES

Chapter 5 TROUBLESHOOTING

5-1. USING THE TROUBLESHOOTING
GUIDE.

5-2. TROUBLESHOOTING GUIDE.

Chapter 6 CORRECTIVE MAINTENANCE

Chapter 1 GENERAL INFORMATION AND SAFETY PRECAUTIONS

Section I. INTRODUCTION

1-1. WELDING PROCESS

GOWELD is the lightest most portable, full-function, smart semi-automatic wire feed welder. GOWELD goes where you go, in the field, in the shop, in the garage. With GOWELD the operator can weld with solid wire electrode and shielding gas (MIG) or self-shielded flux core wire electrode (FCAW). Wire welding is the most economical welding method, due to the high deposition rate, high efficiency, and low equipment cost.

GOWELD uses DC power from 2 (or 3) 12V rechargeable batteries (automobile or deep cycle type) to weld steel or aluminum. GOWELD can also be used as a spool gun for conventional CV welding power sources utilizing an accessory voltage regulator.

GOWELD accommodates 4" (10cm) diameter 2 lb (0.9 kg) spools of .023 (0.6mm) to .045 (1.1mm) diameters wire electrode to weld material in excess of 1/2" (13mm) thick. A trigger operated valve controls the flow of the shielding gas.

GOWELD features a die cast aluminum chassis, heavy duty motor with optical encoder and programmed microprocessor control circuit to monitor feed and weld functions. Together the optical encoder and microprocessor yield speed control with the least variance. LED indicators show power, polarity, low battery warning and motor status.

1-2. WARNINGS AND SAFETY PRECAUTIONS

WARNING

This statement appears where the information must be followed exactly to avoid serious personal injury or loss of life.

CAUTION

This statement appears where the information must be followed to avoid minor personal injury or damage to property.

1-2-1. Warnings.

WARNING

To avoid serious injury or death, all personnel shall heed these warnings.

- a. All users and their supervisory personnel must read and be thoroughly familiar with these operating instructions prior to using this equipment.
- b. Never use the equipment unless you are familiar with acceptable industrial welding and cutting procedures and practices.
- c. Always use this equipment following generally accepted industrial safety procedures and practices.
- d. Always apply and adhere to ANSI/ASC Z49.1-1988 Safety in Welding and Cutting standards, NFPA 51B-1989 Cutting and Welding Processes, and ANSI Z87.1-1989 the Practice for Occupational and Educational Eye and Face Protection, or similar locally prevailing standards when using this equipment.
- e. Never remove, cover, or alter the warning labels attached to this equipment.
- f. Never point the welder at anybody.
- g. Never open the GOWELD housing, no user serviceable parts are within. Always return GOWELD to the factory or an authorized repair facility for major repairs.

- h. Never modify this equipment in any manner or use it in any way not specified in this manual.
- i. Never use any equipment that is unsafe or appears to be unsafe.

1-2-2. Safety Precautions.

WARNING

Failure to heed these safety precautions may result in death, severe bodily injury, or severe property damage. Protect yourself and others. Fumes and gases developed may be dangerous to your health. Ultra-violet rays and splatter can injure eyes and exposed skin. Electric shock can kill. Welding sparks can cause fire or explosion. Compressed gas cylinders may explode if damaged.

NOTE

Vibrations produced by GOWELD during a normal operating cycle do not exceed 2.5m/s^2 , the minimum reportable standard for hand-held and hand-guided machinery.

This equipment produces airborne noise emissions in excess of 70 dB(A). GOWELD sound level has been measured at 74 dB(A) during a normal operating cycle.

- a. Always clear the work area of flammable materials. If this is not possible, cover them to prevent the welding sparks from starting a fire. Always have an approved fire extinguisher in good working condition available.
- b. Never weld in an explosive atmosphere.
- c. Always use extreme caution when operating the welder in windy or other adverse conditions.
- d. Always clear the work area of unnecessary bystanders.
- e. The operator and all bystanders must always wear adequate face and eye protection, protective (flame and/or spark resistant) clothing, footwear, and gloves when using this equipment. Wear oil free protective garments such as leather gloves, heavy shirt,

cuffless pants, high leather steel-toed work shoes, and a cap over your head.

- f. Always use a number 10 or 11 shade welding filter lens when welding or observing welding to protect your eyes from arc rays. Always wear safety glasses with side shields when in a welding area to protect from sparks.
- g. Always wear earplugs when welding in a confined space or out of position. Falling sparks can cause injury.
- h. Always wear approved hearing protection.
- i. Always remove all personal metal items (i.e., rings, watches, etc.) when working with the torch as they can trap sparks and slag causing a severe burn and damage to the item.
- j. Always keep your head away from the fume plume. Welding fumes and gases may be hazardous to your health.
- k. Always use adequate ventilation and exhaust at the arc point to keep fumes and gases from your breathing zone as well as the general area. Special breathing apparatus may be required when welding in confined spaces or when welding or cutting galvanized, cadmium plated (or other heavy metal plated), or painted parts to avoid inhalation of toxic fumes and gases.
- l. Never weld in locations near chlorinated hydrocarbon vapors coming from degreasing, cleaning or spraying operations. Phosgene, a highly toxic gas, may form.
- m. Always use enough ventilation in confined spaces to prevent shielding gases from displacing air and causing injury or death.
- n. Always read and understand the material safety data sheet (MSDS) for the electrode being used with this equipment.
- o. Always consult a physician before welding if you have a pacemaker or history of heart problems.
- p. Always insulate yourself from the work and the ground using dry insulation large enough to cover the full area of physical contact with the work and ground.

- q. Never touch live electrical parts. The welder is “hot” when attached to a battery or other power source. The electrode, electrode reel, welding head, contact tip, nozzle and other exposed metal parts are also “hot.” Never touch these parts with bare skin or wet clothing. Always wear dry, hole-free gloves to insulate hands.
- r. Never lay the welder on top of the work or place it where it can accidentally contact the work or ground or other metal that contacts the work or ground. Electric arc or overheating may result in shock or fire hazard.
- s. Always be sure the ground cable makes a good electrical connection with the metal being welded. The connection should be as close as possible to the area being welded.
- t. Never coil the electrode lead around your body.
- u. Never place your body between the electrode and the ground cable.
- v. Always use a safety belt to prevent a fall should you get a shock when working above floor level.
- w. Always keep the welder away from compressed gas cylinders, and batteries. Protect gas cylinders and batteries from falling sparks or molten metal.
- x. Never heat, cut or weld tanks, drums or containers unless purged with inert gas (such as argon or nitrogen) or other steps have been taken to insure that flammable or toxic vapors are not present.
- y. Always vent hollow castings or containers before heating, cutting or welding to prevent explosion.
- z. Never allow falling sparks or molten metal to contact any part of the welder, its cables or hose. Damage may result which could render the equipment unsafe to operate.
- aa. Always use caution when welding overhead to avoid falling sparks, molten material, and falling objects.
- bb. Never use a high pressure gas cylinder that does not comply with current inspection and testing requirements. Always ensure the

cylinder is marked with a sticker showing a valid inspection certification.

- cc. Always keep high pressure gas cylinders in an upright position, securely chained to a cart or fixed support.
- dd. Never drop a high pressure gas cylinder. Never leave a high pressure gas cylinder in direct sunlight for prolonged periods. Never expose a high pressure gas cylinder to fire or extreme heat. High pressure gas cylinders can be dangerous. Use with caution.
- ee. Always ensure the correct over pressure safety relief device is installed in the high pressure cylinder valve. Never use a safety relief device whose burst pressure is higher than that recommended by the cylinder manufacturer.
- ff. Always keep valve protection caps in place and hand tight except when the cylinder is in use or connected for use.
- gg. Always keep your head and face away from the cylinder valve outlet and regulator when opening the cylinder valve.
- hh. Always use DC power. Never connect AC electric power to this welder.
- ii. Always know the composition of the target material.
- jj. Always know what is behind the target material.
- kk. Always ensure that all parts of the welder are in good working order prior to use to avoid potential malfunction.

See: American National Standard Z49.1-88 Safety in Welding and Cutting published by the American Welding Society, 550 N.W. LeJeune Road; Miami, FL 33126.

“Recommended Safe Practices for the Preparation for Welding and Cutting of Containers and Piping That Have Held Hazardous Substances”, AWS F4.1 from the American Welding Society.

“Precautions for Safe Handling of Compressed Gases in Cylinders,” CGA publication P-1, available from the Compressed Gas Association, 1235 Jefferson Davis Highway, Arlington, VA 22202.

OSHA Safety and Health Standards 29 CFR 1910 available from the U.S.
Department of Labor; Washington, D.C. 20210.

Section 2. EQUIPMENT DESCRIPTION

1-4. GOWELD WELDER FEATURES

1. Dual mode operation- GOWELD can be used as a stand-alone welder with battery power source or as a MIG spool gun for a conventional welder when used with an accessory voltage regulator.
2. GOWELD is designed for 42 volts DC max welding power input, allowing the use of three batteries in series for longer duration or welding steel to 1" (25cm) thick..
3. Die cast aluminum chassis- all hardware is mounted to this internal chassis (frame). It supports the motor, drive assembly, trigger, micro switch, gas valve, circuit board and wire spool.
4. The plastic housing shrouds the working portions of the welder, protecting from exposure and adding visual style.
5. Wire speed control is at the welder's fingertips. Large knob has easy to read numbers. Each graduation represents 100 inches (250cm) per minute (ipm). Operating range of 50 - 1,000 ipm (125 – 2,500 cm/minute).
6. Voltage control dial integral to gun is for use with the accessory voltage control unit, "VCU," to allow reduction of voltage for welding on thin metal.
7. Spring loaded, hinged top cover for easy electrode loading. Over sized knob is easy to grasp while wearing gloves.
8. Heavy duty drive mechanism includes high torque 12 volt industrial motor containing oversized windings and ball bearings to ensure maximum life.
9. Knurled gearing is steel. Tension wheel has ball bearings.
10. Locking cam tension release lever means easy electrode loading. GOWELD does not require application of constant pressure to offset spring loaded tension wheel.
11. Optical encoder fitted to the back of the motor gives true speed readings. More accurate and responsive than back EMF type systems.

12. Programmed microprocessor controls and monitors feed and weld functions. Together the optical encoder and microprocessor yield speed control with the least variance. More consistent speed means more consistent welds. Battery levels are also monitored.
13. Diagnostic capabilities through the control circuit interface cable. No disassembly is required for testing the board, processor or motor.
14. Handle mounted micro switch is more durable than board mounted switches. Micro switch and gas valve are both operated directly off the trigger.
15. LED indicators for power on, polarity, low battery and motor overheat condition.

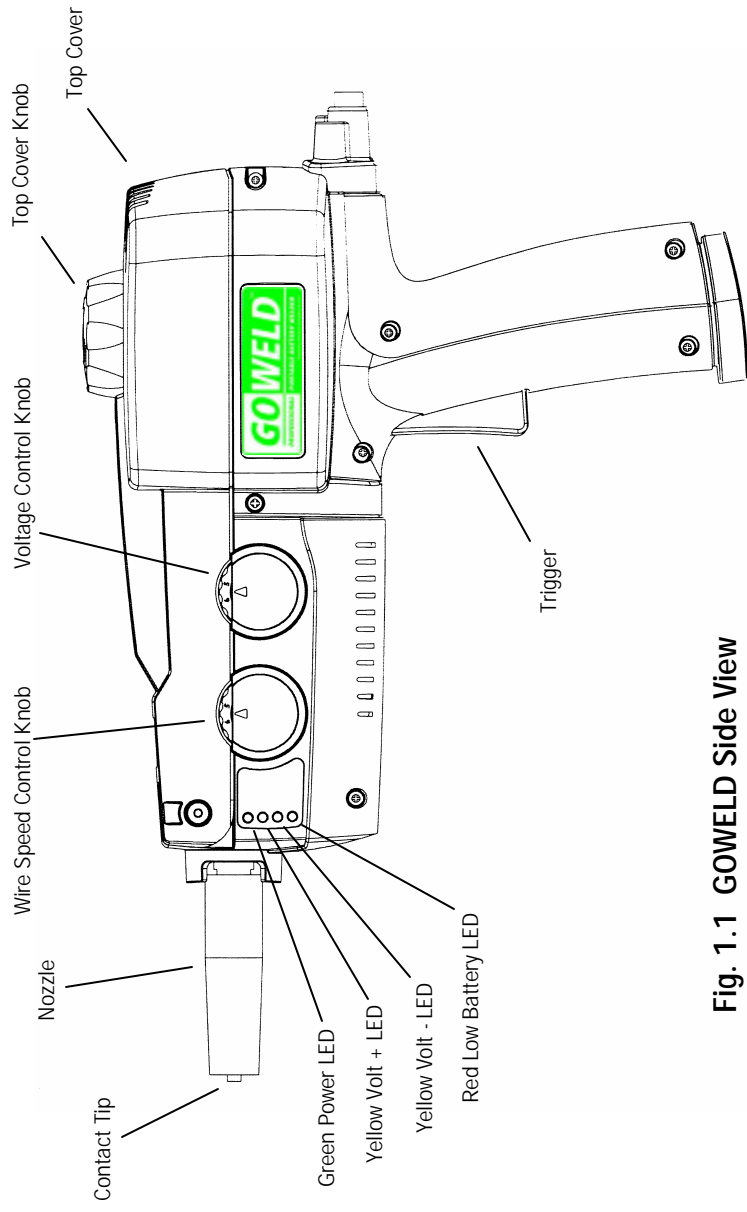

Fig. 1.1 GOWELD Side View

**SAFETY
INFORMATION**

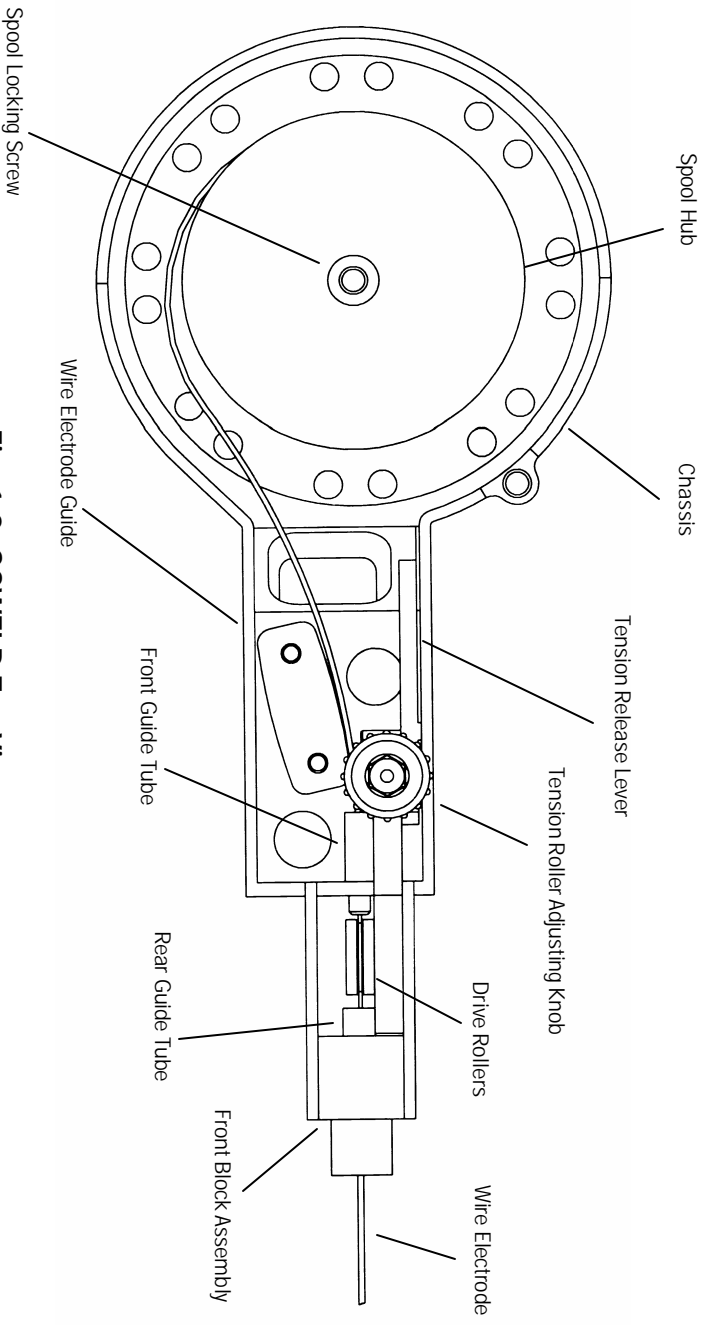

Fig. 1.2 GOWELD Top View

Chapter 2 PREPARATION

Section I. SETUP PROCEDURES

2-1. PREPARING THE WORK AREA

WARNING

Never operate the welder in explosive or flammable environments.

Never operate the welder with other personnel or bystanders in front of the welder or in the immediate work area.

Always use extreme caution when operating the welder in windy or other adverse conditions.

Some plastics, paints, and plated parts give off toxic fumes. Organic materials may be combustible. Exotic metals may ignite. Glass and thin porcelain may shatter. Rock and minerals may spall.

- a. Clear the work area of bystanders/non-essential personnel.
- b. Clear the work area of flammable materials. If this is not possible, cover them to prevent the welding sparks from starting a fire. Always have an approved fire extinguisher in good working condition available.
- c. The operator and all bystanders must always wear adequate face and eye protection, protective (flame and/or spark resistant) clothing, footwear, and gloves when using this equipment. Wear oil free protective garments such as leather gloves, heavy shirt, cuff-less pants, high leather steel-toed work shoes, and a cap over your head.
- d. Place the batteries and gas cylinder in a location away from the immediate work area.
- e. When the target material is a container or pipe, know the material previously contained therein. Always thoroughly purge pipelines and containers with an inert gas (such as nitrogen or argon) prior to welding.
- f. Ensure that falling material (molten metal, sparks, pieces of target material) will not cause injury to operator or bystanders or cause damage to property.

2-2. PRE-SETUP INSPECTION.

WARNING

Never use any equipment which is unsafe or appears to be unsafe.

- a. Always inspect the power cables, gas hose, control circuit cable and electrical connectors for damage or wear prior to and immediately following each use of the welder.
- b. Always inspect the welder for damage or wear prior to and immediately following each use.
- c. Check the battery for leaks. Never use a leaking battery as gases may be toxic and/or combustible. Seepage may be caustic, harming skin and eyes.

Section II. GOWELD SETUP

2-3. LOADING THE WIRE

WARNING

Never load electrode wire or remove or replace the contact tip, gas diffuser, or other parts while the power cables are connected to the batteries or to any other power source.

Always remove the battery cable harness clamps from the batteries before loading electrode wire or removing or replacing the contact tip, gas diffuser or other parts.

NOTE

Tools required are pliers, 1/2" (13mm) open end wrench, 9/16" (14mm) open end wrench and wire cutters (dikes).

2-3-1. Wire selection.

GOWELD can be used with solid steel or aluminum wire or flux-cored steel wire depending upon the job requirements and availability of shielding gas. Solid steel wire (ER70S, AWS SFA5.18) requires the use of "Steel Mix" shielding gas (argon/CO₂ mix); aluminum wire (AWS SFA5.10) requires argon shielding gas; and flux-cored steel wire (E71T, AWS SFA5.20) is gasless.

GOWELD accepts wire sizes from .023" (0.6mm) - .045" (1.1mm) diameter. Choose a size appropriate for the material being welded. As a general rule, GOWELD works best over a wide range of material thicknesses using .030" (0.8mm) or .035" (0.9mm) wire.

2-3-2. Contact tip.

Welding current is transmitted to the electrode through the contact tip. It is important that the orifice in the contact tip is sized to correspond to the diameter of the wire electrode (i.e. use .030" [0.8mm] contact tip with .030" [0.8mm] wire).

Remove the contact tip and the gas diffuser prior to loading the electrode wire.

- a. Remove the nozzle by gripping it firmly in a gloved hand and pulling it straight off the GOWELD.
- b. Remove the nozzle insulator by gripping it firmly with a gloved hand (or pliers if on too tight) and turning it counterclockwise until the threads are clear of the gas diffuser.
- c. Use a 1/2" (13mm) wrench to hold the gas diffuser in place, grip the contact tip with the pliers and turn counterclockwise until disengaged from the gas diffuser. Remove the contact tip.
- d. Use a 9/16" (14mm) wrench to hold the front block extension, while using the 1/2" (13mm) wrench to turn the gas diffuser counterclockwise until the threads are disengaged from the front block extension. Remove the gas diffuser.

2-3-3. Loading electrode / wire drive

- a. Ensure the gas diffuser and contact tip have been removed as per the previous step.
- b. Open the GOWELD top cover by turning the top knob counterclockwise until the threads are disengaged from the spindle. Lift lid carefully until it is fully extended. Do not allow the retention spring to slam the lid open. The retention spring will support the lid, keeping it from falling.

- c. Turn the spool locking screw counterclockwise to reduce the diameter of the spool hub shaft. This will allow the electrode spool to slide over the shaft and rest on the spool hub.
- d. Lift up on the tension release lever to open the gap between the drive roller and tension roller.
- e. While tightly holding the electrode to prevent it from unspooling, cut off the bent end and straighten the first 6 inches (15cm). Cut off the first inch (2.5cm).
- f. Insert the wire end into the front guide tube, pushing it through the gap in the drive rollers and into the rear guide tube until the end of the wire protrudes approximately 2" (5cm) from the front block extension.
- g. Lower the tension release lever to engage the electrode wire with the drive rollers.
- h. Place the roll of electrode wire onto the spool hub with the tailing end coming off the right side to point towards the front of the welder. Make sure the index pin on the spool hub engages a slot on the bottom of the spool. Tear away paper label on spool to expose slot if necessary.
- i. Finger tighten the spool locking screw by turning it clockwise until increased resistance is felt.
- j. Slide the gas diffuser over the wire and thread onto the front block extension. Tighten using the 1/2" (13mm) and 9/16" (14mm) wrenches.
- k. Slide the correct size contact tip over the wire and thread onto the gas diffuser. Use the pliers and 1/2" (13mm) wrench to tighten.
- l. Replace the insulator, finger tighten.
- m. Replace the gas nozzle by pressing it on to the front of the welder. Adjust nozzle setback to allow for appropriate wire stick out for electrode type and size.

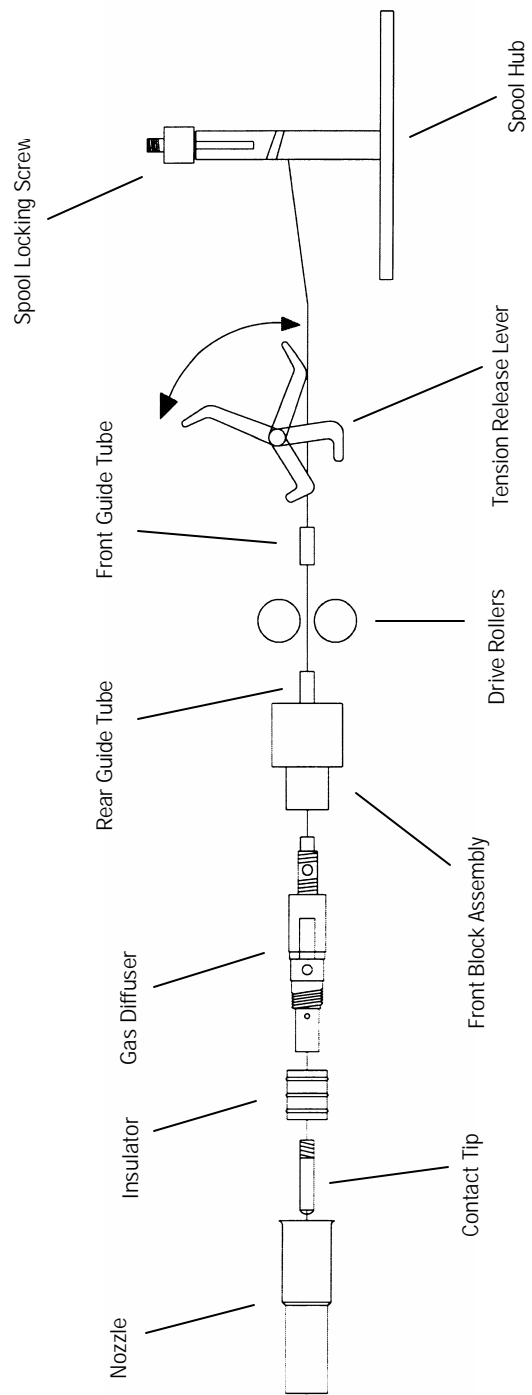

Fig. 2.1 Wire Electrode Path

PREPARATION

2-3-4. Tension roller pressure setting.

| |
|-------------|
| NOTE |
|-------------|

The tension roller pressure is set at the factory to accommodate .035" (0.9mm) flux cored wire.

- a. Set the tension roller pressure as light as possible to maintain a continuous feed while minimizing wire distortion.
- b. The knurled adjusting knob rotates counterclockwise to reduce pressure and clockwise to increase pressure.
- c. With the wire loaded and the power cables attached point the welder at a non-conductive hard object (a concrete floor or wall for example) with the contact tip approximately two inches from the surface.
- d. Depress the trigger causing wire to beginning spooling out at low speed, approximately 100 inches (250cm) per minute. As the wire hits the surface it should be turned aside, coiling the wire.
- e. Slowly turn the adjusting knob counterclockwise until the wire begins to slip in the rollers. Remove pressure from the trigger to shut down the drive system.
- f. Turn the adjusting knob ½ turn clockwise.
- g. Test to ensure there is no longer any slippage by again depressing the trigger and observing the wire and spool.

2-4. CABLE CONNECTIONS

2-4-1. Harness to power source.

| |
|----------------|
| WARNING |
|----------------|

Never allow the GOWELD to unintentionally contact any part of the workpiece or other surface that may be grounded into the welder circuit as electric shock may occur. Once the GOWELD has been attached to the

power source the electrode is always "hot." The trigger controls the drive motor and gas flow only, GOWELD does not have an internal contactor.

NOTE

If the clamps are not on the proper terminal, the gun will not operate. When the cables are correctly attached to the batteries and the green LED power indicator will light and the motor will operate when the trigger is depressed. If the clamps are attached to the wrong terminals on the batteries the LED indicator will not light and the motor will not operate.

PREPARATION

2-4-1-1. Batteries.

NOTE

GOWELD's control circuit input must be kept to only 24 volts DC. Welding power can be from a combination of two (or three) 12v batteries.

Using 2 batteries. (24 volt welding power)

- a. Join the batteries in series using the jumper cable provided. Attach one end of the cable to the positive terminal of the first battery and the other end of the cable to the negative terminal of the second battery.
- b. Attach the black (negative-) clamp to the open negative (-) terminal on the first battery.

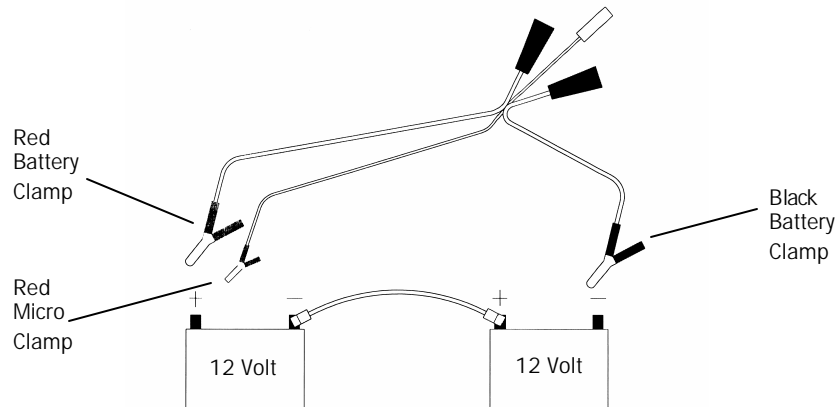

Fig. 2.3 GOWELD Harness To Two Batteries

- c. Attach the red (positive+) clamp to the open positive (+) terminal on the second battery.
- d. Attach the red micro clamp to the positive (+) terminal of the second battery.

Using 3 batteries. (36 volt welding power)

NOTE

While welding power can be 36 volts, input power to the welder control circuit must be 24 volts. The red micro clamp is for control circuit power input only.

- a. Join the batteries in series using the jumper cable provided and a second cable (one element of an automotive jumper cable set may be used). Attach one end of the cable to the positive terminal of the first battery and the other end of the cable to the negative terminal of the second battery. Attach one end of the second cable to the positive terminal of the second battery and the other end of that cable to the negative terminal of the third battery.
- b. Attach the black (negative-) harness clamp to the open negative (-) terminal on the first battery.

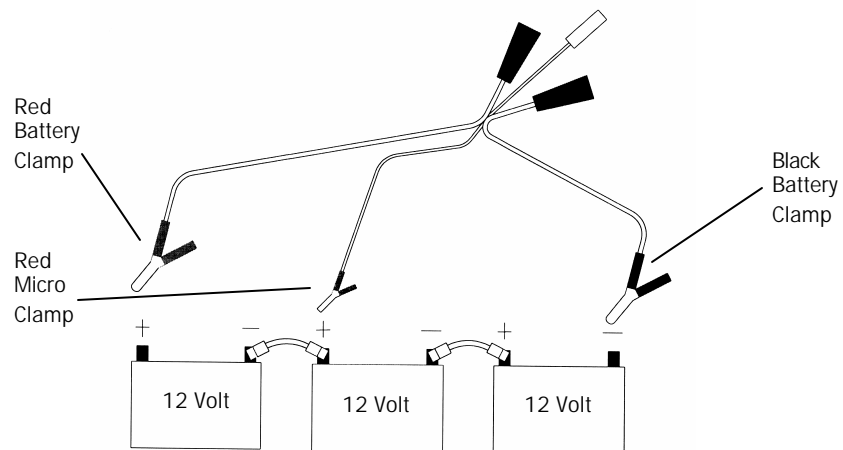

Fig. 2.4 GOWELD Harness To Three Batteries

- c. Attach the red micro clamp to the positive (+) terminal of the second battery.
- d. Attach the red (positive+) harness clamp to the open positive (+) terminal on the third battery.

2-4-2. GOWELD to harness.

Connect the GOWELD to the power harness by plugging the 5-pin control cable connectors together and mating the appropriate welder power and ground cable connectors with the harness cable connectors.

PREPARATION

2-4-2-1. Choosing polarity.

- ? **Solid steel electrode-** weld with Reverse polarity, electrode (welder) positive, ground cable negative.
- ? **Stainless steel electrode-** weld with Reverse polarity, electrode (welder) positive, ground cable negative.
- ? **Flux-core self shielding steel electrode-** weld with Straight polarity, electrode (welder) negative, ground cable positive.
- ? **Aluminum-** weld with Reverse polarity, electrode (welder) positive, ground cable negative.
- ? **Flux-core hardfacing wire-** weld with Reverse polarity, electrode (welder) positive, ground cable negative.

2-4-2-2. Power & ground leads.

- a. Straight polarity- mate the welder power cable connector with the connector attached to the black (negative) battery clamp. Mate the ground cable connector with the connector attached to the red (positive) battery clamp.
- b. Reverse polarity- mate the welder power cable connector with the connector attached to the red (positive) battery clamp. Mate the ground cable connector with the connector attached to the black (negative) battery clamp.

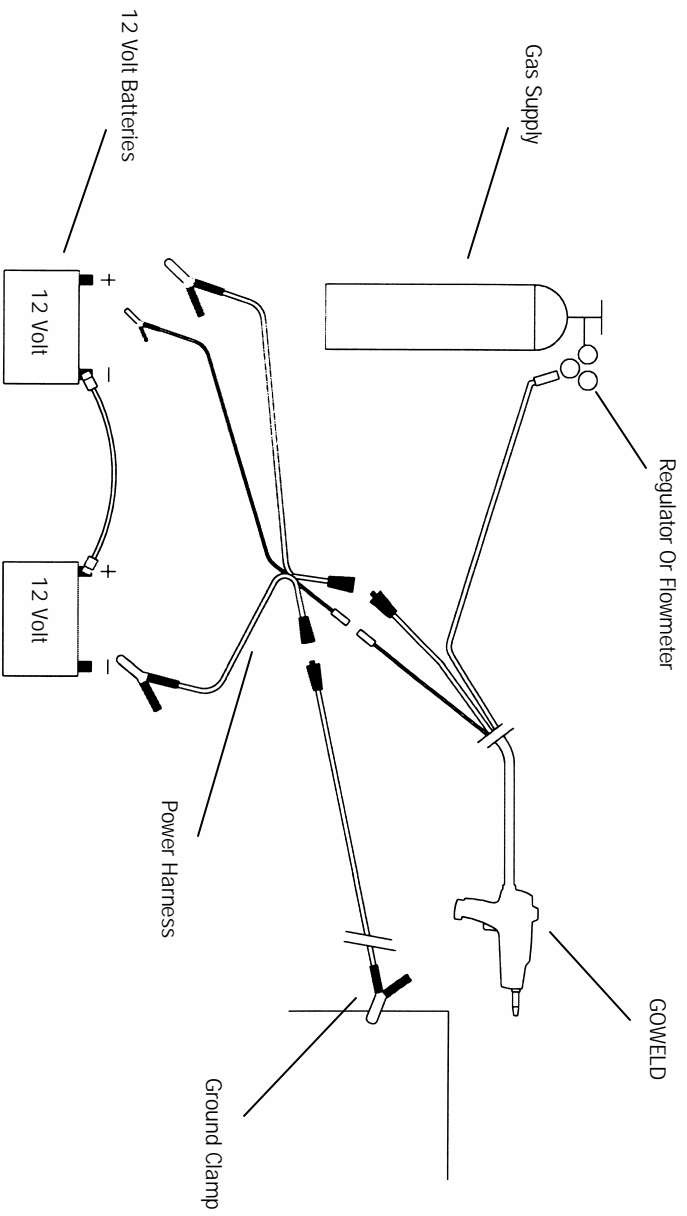

Fig. 2.5 GOWELD System Setup
(Two battery reverse polarity illustrated.)

2-4-3. Ground cable to work.

WARNING

Never position the ground cable where the operator's body can come between the work and the ground. Always position the ground cable away from the welder.

Attach the ground cable clamp to the item being welded. Be sure that the clamp is secure and that it is positioned away from the operator.

2-5. GAS CONNECTIONS

2-5-1. Gas hose connection.

GOWELD has a "B" size inert gas fitting on the gas hose. Attach the GOWELD hose to the regulator or flow meter outlet fitting by threading the nut into the fitting. If the regulator fitting has a male thread, a FEM "B"-FEM "B" adaptor will be required.

2-5-2. Regulator adjustment.

WARNING

Never stand directly in front of or directly behind the gas regulator while opening the gas cylinder valve to reduce the risk of injury in the unlikely event of regulator failure.

- a. Shielding gas flow rate should be set to approximately 20cfh.
- b. Open the gas cylinder valve slowly.
- c. Slightly depress the GOWELD trigger to begin the flow of gas. Do not press so far that the wire feed motor is activated.
- d. With the gas flowing, adjust the regulator delivery pressure to 20 psig (1.5 bar) or the flow meter indicator to 20 cfh.
- e. Release the trigger to stop the flow of gas.

Chapter 3 OPERATING INSTRUCTIONS

Section I. INTRODUCTION

3-1. GOWELD OPERATION

| |
|----------------|
| WARNING |
|----------------|

Never operate the welder in explosive or flammable environments.

Never operate the welder with other personnel or bystanders in front of the welder or in the immediate work area.

Always use extreme caution when operating the welder in windy or other adverse conditions. Nearby organic materials may be combustible.

Never breathe welding fumes. Some plastics, paints, and plated parts give off toxic fumes.

The welder operates on the following principle. GOWELD conducts electrical energy from a set of batteries through an alloy wire welding electrode to a grounded workpiece, causing the tip of that electrode to go molten in the arc and transfer to the work where it fuses with the base material creating a buildup of alloy filler material (the "weld"). A pair of control knobs allow the operator to set the electrode wire feed speed (range 0" – 1000" [2,500cm] per minute) and (when the optional remote voltage control unit is installed) adjust the welding voltage. The trigger opens the gas valve so that gas will flow out the tip of the unit to surround the welding wire and shield the weld puddle. The trigger also operates the micro switch which enables the wire feed motor.

3-2. WELDING CAPABILITY

Welding duration is dependent upon the batteries being used as the power source. Larger capacity deep cycle 12v batteries will provide the most welding "arc time" between charges. On average 10-20 minutes of welding arc time can be performed with GOWELD on one set of batteries.

GOWELD operates at 50% duty cycle, which means GOWELD can be used for 5 minutes of arc-time in a 10 minute period to stay within the operating temperature parameters.

GOWELD will accommodate welding wire of .023" (0.6mm) -.045" (0.9mm) diameter. GOWELD can be used to weld material ranging from 1/8" (3mm) thickness to 1" (25mm).

GOWELD can be used to weld with:

- ? Steel- Solid wire
- ? Steel- Self shielding wire
- ? Aluminum- Solid wire
- ? Stainless- Solid wire
- ? Hardfacing- Cored wire

3-3. CONTROLS & SETTINGS

3-3-1. Wire speed control.

The wire speed control is indexed to the value on the control knob X100. Example: The "4" mark on the knob correlates to approximately 400 inches per minute (ipm).

Turning the knob clockwise increases the wire speed while turning the knob counter-clockwise decreases wire speed.

There is a direct relationship between welding wire speed and the welding current (in amps). As the wire speed changes up or down the welding current changes in the same direction (up or down).

Optimum speed will result in a stable arc, smooth transfer of weld material to the work, good bead profile, good penetration and constant stick-out.

OPERATION

3-3-2 Voltage Control.

The accessory voltage control unit is installed in the welding circuit between the GOWELD and the battery power source. The voltage control unit reduces the welding voltage with minimum power loss to facilitate welding thin gauge metals without burn through.

See "Voltage Control Installation & Operation Instructions" which are included with the accessory voltage control unit.

3-3-3 LED INDICATORS

There are 4 LED indicators on the GOWELD unit and their operation is as follows:

- ? **Green "POWER"** LED will illuminate when control circuit power is supplied to the GOWELD through the control cable. The voltage supplied must be 24vDC for proper operation. The green LED will flash slowly to indicate motor overheat condition. When the motor has cooled sufficiently the green LED will return to a steady light. The green LED will flash rapidly in the case of wire jam to indicate the motor is not turning. (See 3-6-1 & 3-6-2.)
- ? **Yellow "Volt+" and "Volt-"** LEDs are welding polarity indicators. When the welding power to the GOWELD is connected to either the + or – terminal of the supply battery, one of these LEDs will come on to indicate the polarity of that connection. (See 2-4-2-1.)
- ? **Red "Low Battery"** LED is normally off. As the battery voltage drops during use, this LED will begin to flash. The rate of flashing will increase as the voltage drops closer to the preset low battery limit (14 volts for two batteries and 21 volts for 3 batteries) . The flashing will stop with the LED on continuously when the voltage drops below the low battery limit. If the trigger was on when the low battery limit is reached, the motor will stop automatically in order to prevent damage to the batteries from discharging them too far. When this condition is active, the LED will stay on until the trigger is released at which time the LED will begin to flash again as the batteries recover. The low battery limit is established at 19 volts for a 2 battery system and 29 volts for a 3 battery system. (See 3-6-3.)

3-4 SEQUENCE OF OPERATION

WARNING

Never use the equipment unless you are familiar with acceptable industrial welding and cutting procedures and practices.

Always use this equipment following generally accepted industrial safety procedures and practices.

The operator and all bystanders must always wear adequate face and eye protection, protective (flame and/or spark resistant) clothing, footwear, and gloves when using this equipment. Wear oil free protective garments such

as leather gloves, heavy shirt, cuffless pants, high leather steel toed work shoes, and a cap over your head.

Always use a number 10 or 11 shade welding filter lens when welding or observing welding to protect your eyes from arc rays. Always wear safety glasses with side shields when in a welding area to protect from sparks. Always keep your head away from the fume plume. Welding fumes and gases may be hazardous to your health.

Always use adequate ventilation and exhaust at the arc point to keep fumes and gases from your breathing zone as well as the general area. Special breathing apparatus may be required when welding in confined spaces or when welding or cutting galvanized, cadmium plated (or other heavy metal plated), or painted parts to avoid inhalation of toxic fumes and gases.

Always use enough ventilation in confined spaces to prevent shielding gases from displacing air and causing injury or death.

Never lay the welder on top of the work or place it where it can accidentally contact the work or ground or other metal that contacts the work or ground. Electric arc or overheating may result in shock or fire hazard.

Always insulate yourself from the work and the ground using dry insulation large enough to cover the full area of physical contact with the work and ground.

1. Check/prepare the work area.
2. If a shielding gas is to be used, attach the regulator to the gas cylinder then connect the gas line to the regulator. Set the regulator to the appropriate gas delivery pressure.
3. Attach the jumper cable to the batteries.
4. Attach the harness to the batteries.
5. Attach the ground clamp to the work.
6. Load the wire electrode.
7. Check to see that the selected contact tip is the appropriate size for the electrode being used. Install the diffuser, contact tip and nozzle.

8. Connect the GOWELD control circuit cable.
9. Set the wire feed speed as per section 3-3-2.
10. Connect the GOWELD welding power cable and ground cable to the harness making sure the polarity is appropriate for the electrode being used.
11. Bring the welder into position near the work piece.
12. Ensure eye protection is in place. Make sure auto darkening lenses are turned "on".
13. Squeeze the trigger to commence welding.
14. To stop welding release the trigger and pull GOWELD away from the work.

3-5 WELDING TECHNIQUES

- ? Position the tip of the electrode over the place on the work where the weld is to start.
- ? Hold GOWELD so the angle of the welder relative to the length of the weld is approximately 10° - 25° from vertical. The angle of the welder relative to the plate is approximately 45° for fillet welding or 5° from vertical for a beveled butt joint.
- ? Use the backhand method (where the wire feeds opposite the direction of travel, filler metal is deposited into the previous weld-drag) for flat, horizontal, overhead and vertical down welding positions.
- ? Use the forehand method (where the wire feeds in the direction of travel, filler metal is deposited directly on the workpiece- push) for the vertical up welding position.
- ? Travel speed should be between 10" (25cm) per minute and 13" (33cm) per minute. Vary the travel speed while welding a test coupon to determine the rate that yields the best penetration for that application and the operator's technique.

- ? Wire stickout (the distance from the contact tip to the work) should be maintained at between 3/8" (9mm) and 3/4" (19cm) depending upon the electrode type and size, wire feed speed and material thickness. Generally a longer stickout and high wire feed speed are preferable for welding thin materials, while less stickout will increase penetration.
- ? Torch manipulation ("weaving") allows the operator to obtain the desired fill with a minimum number of passes. As a general rule a small circular motion is recommended for fillet welds. A back-and-forth weave with a slight pause at the sides is typically used for butt weld root passes and fill passes. Adjust the weave for the desired width of the resultant weld.

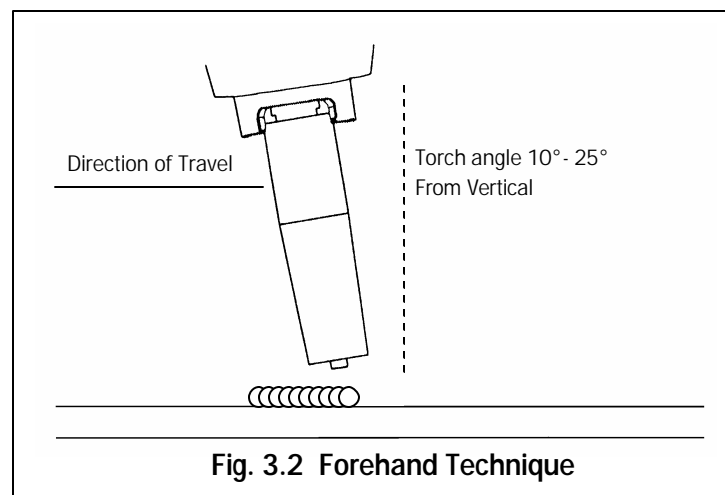
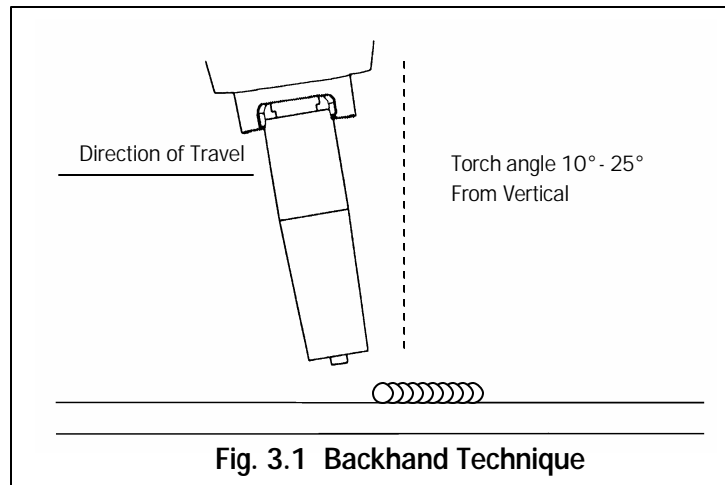

OPERATION

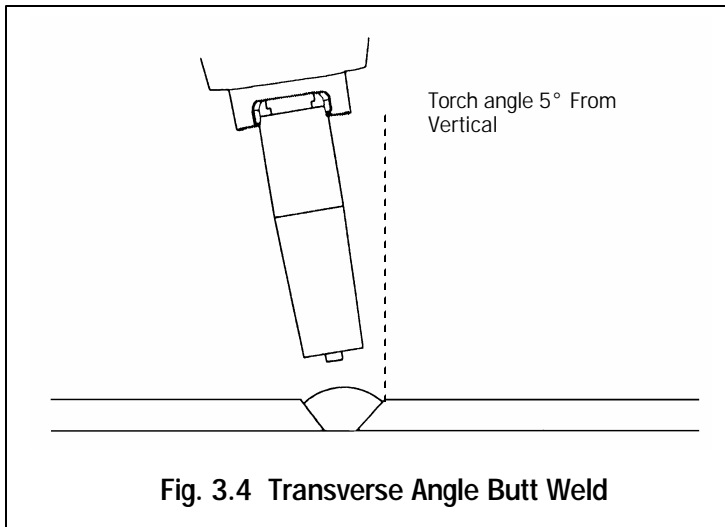
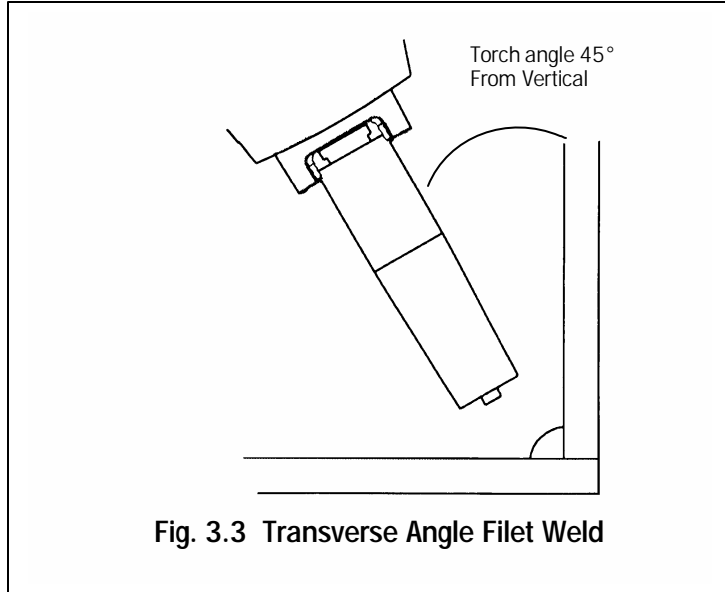

Position variations:

- Vertical up- Butt weld root passes are made with a slight "U" pattern. Fill passes are made using a side to side weave with a very slight backstep at the sides. Fillet welds are made using an inverted angle, up to the center then down to the opposite side, pause, up to the center and so on.
- Vertical down- An inverted "u" is used for butt weld root and fill passes and fillet welds. Keep the arc on the leading edge of the puddle for best penetration.
- Overhead- Butt weld root, fill and cover passes and fillet welds are all made using a back and forth weave with a slight pause at the sides.

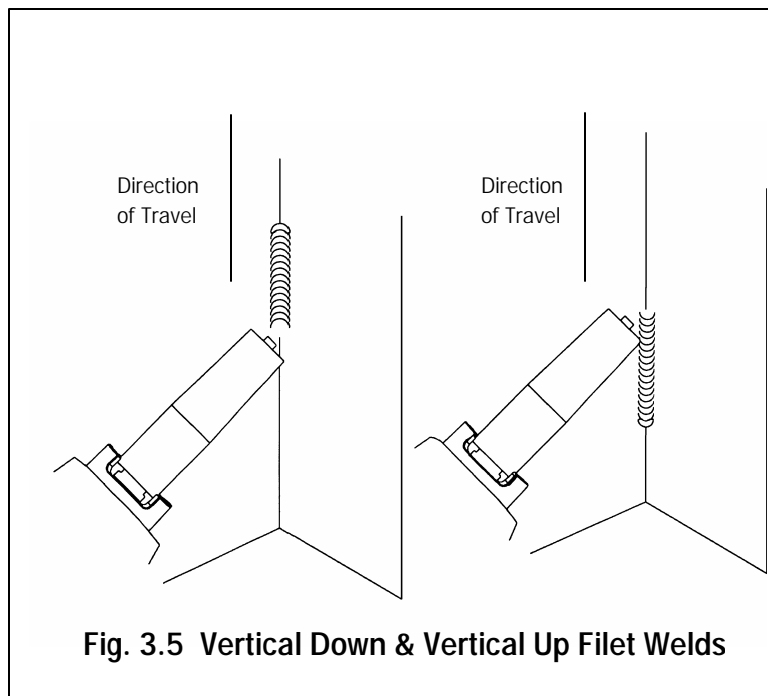

OPERATION

3-6 AUTOMATIC PROTECTION SHUTDOWN

| |
|-------------|
| NOTE |
|-------------|

GOWELD has been designed to automatically shut down to prevent damage to GOWELD's motor, circuits or the batteries. In the event GOWELD appears to cease operation while welding look first to one of the following conditions.

3-6-1 OVERHEAT PROTECTION

GOWELD's motor is equipped with an external thermister which continuously sends temperature data to the microprocessor.

When the motor temperature reaches 100°C the overheat protection program will shut the motor off.

Overheat protection is indicated by the slowly flashing green "power" LED.

Allow GOWELD to cool a few minutes then continue welding.

3-6-2 WIRE JAM CONDITION

In the unlikely event of a wire jam preventing the welder's motor from turning while the trigger is being pulled, the microprocessor will cease sending current to the motor to prevent damage to the motor or other components.

Wire jam condition is indicated by the rapidly flashing green "power" LED.

Disconnect the welder from the batteries, open the GOWELD top cover, remove the jammed wire, check the wire path and reload the wire.

3-6-3 LOW BATTERY CONDITION

Rechargeable batteries can often be damaged by depleting them too far before charging, shortening battery life. GOWELD's microprocessor monitors battery voltage level and causes a shutdown before the voltage drops to potentially damaging levels.

When the combined voltage of the two batteries falls below 19 volts while welding (29 volts for three batteries), the red "low battery" LED will begin to flash. The rate of flashing will increase as the voltage drops closer to the preset low battery limit.

When the combined voltage of the two batteries falls to 14 volts (21 volts for three batteries), GOWELD's battery protection program will shut the motor off. The red "low battery" LED will remain constantly "on" while the trigger is depressed.

Recharge the batteries or exchange for a fresh set to resume welding.

3-7 SHUTDOWN PROCEDURES

1. Remove the cable harness from the batteries.
2. Disconnect the GOWELD power cable and ground cable from the harness.
3. Disconnect the control circuit cable from the harness. Grasp the connector firmly in both hands. Depress the locking tab while pulling straight apart. Do not pull on the wires.
4. Close the gas cylinder valve. Depress the trigger to relieve the pressure from the gas hose. Disconnect the gas hose from the regulator and remove the regulator from the cylinder. (Replace the cylinder valve protector cap.)
5. Cut off the melted end of the electrode wire.
6. Open the GOWELD top cover by turning the top knob counterclockwise until the threads are disengaged from the spindle. Lift lid carefully until it is fully extended. Do not allow the retention spring to slam the lid open. The retention spring will support the lid, keeping it from falling.
7. Twist the spool locking screw counterclockwise to reduce the diameter of the spool hub shaft.
8. Remove the electrode spool from the spool hub while keeping tension on the wire to prevent "bird nesting."

9. While keeping pressure on the wire with a finger, raise the on the tension release lever to open the gap between the drive roller and tension roller.
10. Pull back on the wire to remove it from the GOWELD front end. Secure the free end of the electrode through a hole in the spool for storage.
11. Lower the tension release lever.
12. Wipe the inside of the GOWELD with a clean dry cloth to remove any dust or debris. Close and secure the lid.
13. Remove the nozzle and clean the nozzle, tip and torch front end.
14. Remove the jumper cable from the batteries.
15. Wipe the GOWELD, cables and accessories with a clean cloth and replace in the carrying case.
16. Charge the batteries according to the instructions for the batteries in use and the appropriate battery charger.

Chapter 4 SCHEDULED MAINTENANCE

Section I. INTRODUCTION

4-1. PREVENTIVE MAINTENANCE

Preventive maintenance is the responsibility of the equipment operator.

Preventive maintenance should be conducted in accordance with this manual and consist of inspecting, servicing, and cleaning. Inspections will also reveal the need for repairs. Periodic inspections will ensure the welder is safe and serviceable. Regulator repairs should only be performed by qualified technicians.

Section II. SCHEDULED MAINTENANCE

4-2. PREVENTIVE MAINTENANCE PROCEDURES

WARNING

Prior to conducting any maintenance, ensure proper shut down procedures are followed.

Never touch electrically hot parts.

Never operate GOWELD with the covers removed.

Always disconnect the welder power and ground cables from the battery when GOWELD is not in use.

1. After each use wipe the welder, cables, cable harness, gas hose regulator, battery jumper cable, and batteries with a clean dry cloth.
2. Remove the nozzle and contact tip, inspect for damage and wear. Clean, replace if necessary, and reassemble.
3. Before and after each use, conduct a close inspection of the cables and hoses. Check for cuts, burns, or any other sign of damage or wear. After every use, wipe down all cables and hoses with a clean, oil-free cloth.

4. Wipe the interior of the GOWELD with a clean dry cloth.
5. Every six months, or following a period of heavy use:
 - a. Remove the plastic lid and handle halves and inspect the circuit board, motor and drive assembly. Gently blow accumulated dirt from all components using compressed air.
 - b. Lubricate the gear teeth with a small amount of high temperature resistant grease. Use caution to avoid getting grease on the drive roller surface.
 - c. Do not use any solvents to clean the tension roller because it may wash the lubricant out of the bearings.
 - d. Do not lubricate the spool hub or friction pad.

Chapter 5 TROUBLESHOOTING

5-1. USING THE TROUBLESHOOTING GUIDE.

This guide is intended to assist in determining the probable causes of torch malfunctions and their associated repairs. For each potential problem identified, a probable cause and recommended repair procedure is listed.

5-2. TROUBLESHOOTING GUIDE.

| TYPE OF PROBLEM / MALFUNCTION | PROBABLE CAUSE | RECOMMENDED REPAIR PROCEDURES |
|---|---|--|
| 1. "POWER" LED DOES NOT LIGHT. NOTHING HAPPENS WHEN THE TRIGGER IS DEPRESSED. | a. The cable harness clamps are not connected to the correct battery terminals. OR b. The control circuit power cable red micro clamp is not connected to the positive (+) battery terminal. OR c. The battery jumper cable may be damaged or missing. OR d. The control circuit cable connector is not plugged in to the cable harness or damaged. | Double check the harness clamp connections with the batteries, the battery jumper cable connection, and the control cable circuit plug connection. |
| 2. "POWER" LED LIGHTS BUT MOTOR DOES NOT RUN WHEN THE TRIGGER IS PULLED. | a. Batteries may not have sufficient charge. (Accompanied by blinking red "Low Power" LED.) OR b. Overheat protection may be shutting motor off. (Accompanied by slowly flashing green "Power" LED.) | Check the batteries' condition of charge. Replace if necessary. Allow GOWELD to cool a few minutes until green LED stops blinking. |

TROUBLESHOOTING

| | | |
|---|--|--|
| <p>3. POLARITY INDICATOR LED DOES NOT COME ON.</p> | <p>OR c. Wire jam protection may be shutting motor off (accompanied by rapidly flashing green "Power" LED.)</p> <p>a. The welder power cable is not correctly connected to the cable harness or damaged.</p> <p>OR b. The large red clamp is not connected to the positive (+) battery terminal.</p> | <p>Clear the wire jam, inspect the wire path and reload the electrode.</p> <p>Double check the welder power cable connection to the harness. Make sure all battery connections are correct.</p> |
| <p>4. THERE IS NO ARC BETWEEN THE ELECTRODE AND THE WORK.</p> | <p>a. The ground is not correctly attached to the work or damaged.</p> <p>OR b. The ground cable connector is not correctly connected to the cable harness.</p> | <p>Double check the ground cable connection to the harness. Make sure the ground clamp is securely attached to the work, with good metal-to-metal contact.</p> |
| <p>5. THE MOTOR RUNS BUT THE WIRE DOES NOT FEED SMOOTHLY.</p> | <p>a. The drive roller tension adjustment may be too loose.</p> <p>OR b. The wire may be tangled on the spool.</p> <p>OR c. The contact tip may be clogged.</p> <p>OR d. The drive rollers may be contaminated with excess dirt, residue or grease.</p> | <p>Check drive roller tension adjustment as per section 2-3-4 above.</p> <p>Inspect the wire spool for tangles, replace if necessary.</p> <p>Clean or replace the contact tip.</p> <p>Clean drive rollers.</p> |

| | | |
|--|---|--|
| <p>6. THE WELDING ARC IS UNSTEADY, INTERMITTENT.</p> | <p>a. Batteries may not have sufficient charge. (Accompanied by blinking red "Low Power" LED.)</p> <p>OR</p> <p>b. The contact tip is dirty, worn or the wrong size.</p> <p>OR</p> <p>c. The wire speed is set too low.</p> <p>OR</p> <p>d. The ground connection is not making sufficient contact with the work.</p> <p>OR</p> <p>e. The metal to be welded has not been sufficiently cleaned of oil, paint or rust.</p> | <p>Check the batteries' condition of charge. Replace if necessary.</p> <p>Clean or replace the contact tip.</p> <p>Increase the wire speed/amperage.</p> <p>Make sure the ground clamp is securely attached to the work, with good metal-to-metal contact.</p> <p>Ensure the metal to be welded is clean, with all paint, rust and oils removed.</p> |
|--|---|--|

Chapter 6 CORRECTIVE MAINTENANCE

Major repairs to the GOWELD including but not limited to circuit board testing and replacement, motor replacement and drive assembly replacement should only be done by the factory or its authorized repair center. Contact Broco, Inc. at (800) 845-7259, (909) 483-3222, Fax (909) 483-3233, e-mail Broco@att.net for return authorization or other repair information.

--NOTES--