

ECM Power Source Circuit

CIRCUIT DESCRIPTION

When the ignition switch is turned on, battery positive voltage is applied to terminal IGSW of the ECM and the EFI main relay (Marking: EFI) control circuit in the ECM sends a signal to terminal MREL of the ECM switching on the EFI main relay.

This signal causes current to flow to the coil, closing the contacts of the EFI, main relay and supplying power to terminals +B of the ECM.

If the ignition switch is turned off, the ECM continues to switch on the EFI main relay for a maximum of 2 seconds for the initial setting of the IAC valve.

WIRING DIAGRAM

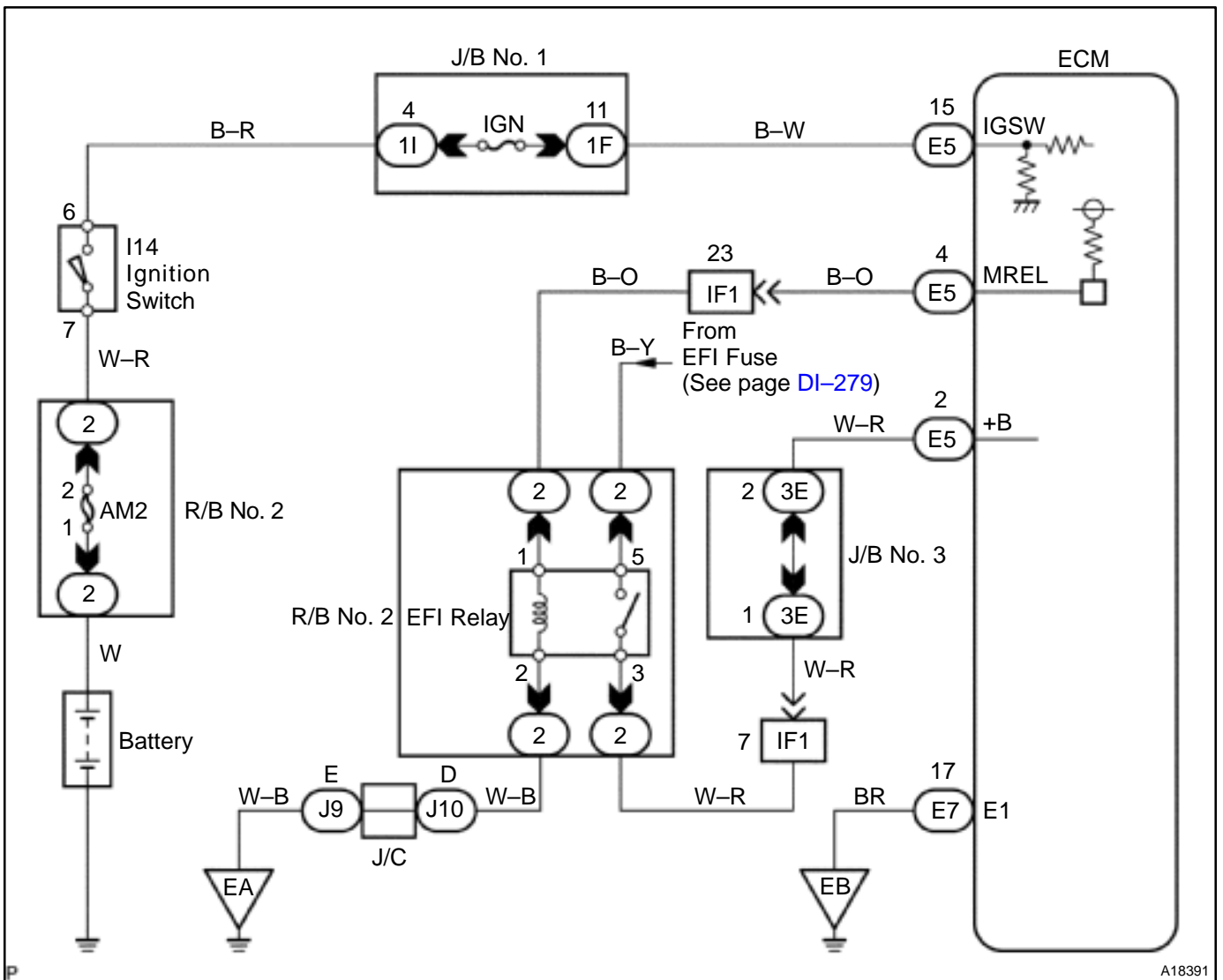

INSPECTION PROCEDURE

1 Check voltage between terminals +B and E1 or ECM connectors.

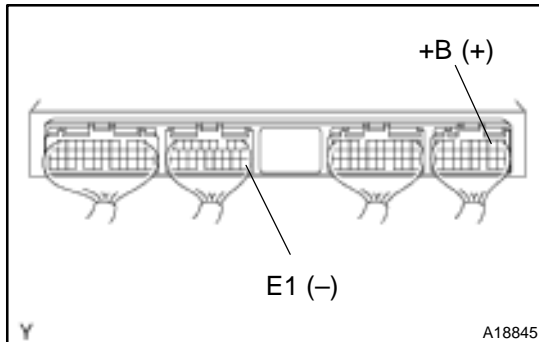
**PREPARATION:**

- (a) Remove the glove compartment (See page SF-58).
- (b) Turn the ignition switch ON.

CHECK:

Measure the voltage between terminals +B and E1 of the ECM connectors.

OK:

Voltage: 9 – 14 V

OK

Proceed to next circuit inspection shown on problem symptoms table (See page DI-174).

NG

2 Check for open in harness and connector between terminal E1 of ECM connector and body ground (See page IN-28).

NG

Repair or replace harness or connector.

OK

3 Check voltage between terminal IGSW of ECM connector and body ground.

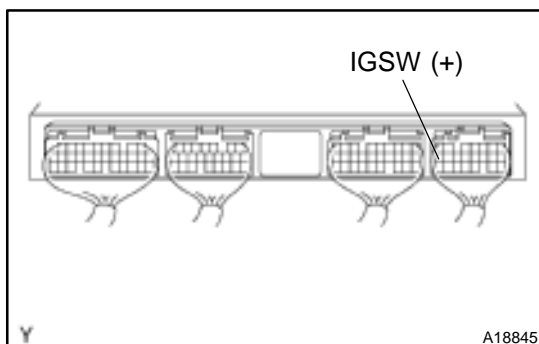
**PREPARATION:**

- (a) Remove the glove compartment (See page SF-58).
- (b) Turn the ignition switch ON.

CHECK:

Measure the voltage between terminal IGSW of the ECM connector and the body ground.

OK:

Voltage: 9 – 14 V

OK

Go to step 6.

NG

4 Check IGN fuse.

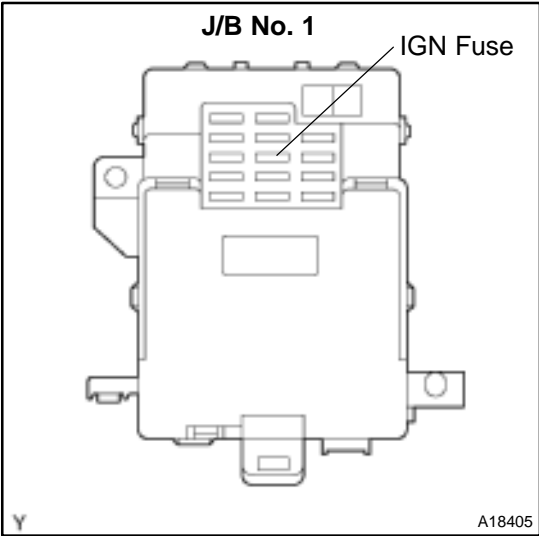

PREPARATION:
Remove the IGN fuse from the J/B No. 1.

CHECK:
Check the continuity of the IGN fuse.

OK:
Continuity

NG → **Check for short in all harness and components connected to IGN fuse (See attached wiring diagram).**

OK

5 Check ignition switch (See page BE-13).

NG → **Replace ignition switch.**

OK

Check and repair harness and connector between battery and ignition switch, and ignition switch and ECM (See page IN-28).

6 Check voltage between terminal MREL of ECM connector and body ground.

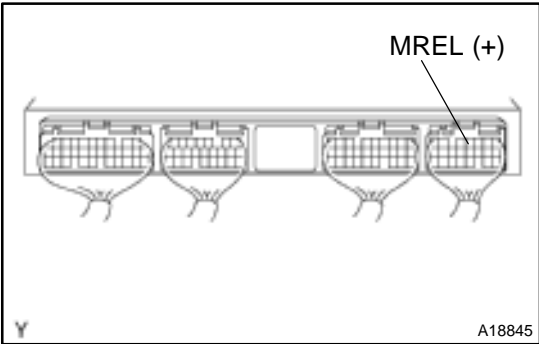

PREPARATION:
(a) Remove the glove compartment (See page SF-58).
(b) Turn the ignition switch ON.

CHECK:
Measure the voltage between terminal MREL of the ECM connector and the body ground.

OK:
Voltage: 9 - 14 V

NG → **Check and replace ECM (See page IN-28).**

OK

7 Check EFI fuse (See page [DI-279](#), step 2).

NG

Check for short in all harness and components connected to EFI fuse (See attached wiring diagram).

OK

8 Check EFI main relay (Marking: EFI) (See page [SF-40](#)).

NG

Replace EFI main relay.

OK

9 Check for open and short in harness and connector between terminal MREL of ECM and body ground (See page [IN-28](#)).

NG

Repair or harness or connector.

OK

Check and repair harness or connector between EFI fuse and battery.